



# Electric Forklift

A series 4-wheel 1.5-3.5t

A series reach truck 1.5-2.5t

M series 3-wheel forklift 1.6-2t

M series rear drive 3-wheel forklift 1.6t



Electric Forklift



Zhejiang Maximal Imp& Emp Co.Ltd

Address: Room 1408, East Building, Zancheng  
Center, No.9 Feiyunjiang Road, Shangcheng  
District, Hangzhou, China

Tel: 0086-571-28815951 0086-571-28001566  
0086-571-28979901

**Email**

info@max-mhe.com (For sales)  
parts@max-mhe.com (For spare parts)

Website: [www.max-mhe.com](http://www.max-mhe.com)

All rights reserved. If any doubt, please contact us.



# maximal

# MAXIMAL FAMILY



*We work for maximal*



# Maximal Company Introduction



Established in Feb. 2006, Maximal Forklift (zhejiang) Co., Ltd, is located in Lushan Industry Area with convenient transportation. Maximal specializes in material handling equipment designing and manufacturing.

Maximal Company total floor area is 133,334㎡, investment RMB420 million, factory designed production capacity is 30000 units per year.

Currently Maximal employs 500 staffs, with more than 230 professional and technical personnel, more than 70 Technical R&D personnel. Maximal gained 7 national invention patents, more than 70 utility model and appearance patents.

Maximal owns advanced parts processing center, robot welding equipments, parts automatic hoist conveyor lines, coating lines, assembly lines, forklifts performance test lines, parts test-bed and ERP information management system.

Maximal current product range covers 4 series, including 1.5-compact 12T industrial forklift, 1.8-5.0T rough terrain forklift, 13.5-32.0T heavy duty forklift, side loader forklift & Port machinery and warehouse equipment.

Maximal forklifts received strong public recognition for their modern and striking appearance, high production quality, safety standard and low cost of operation.

At present, Maximal products sales have covered all provinces in domestic market, exported to over 100 countries and areas.

Maximal takes "technology innovation, promoting products structure, improving product quality and service" as the belief, takes internationalization, professionalization and green environmental protection as mission, to build Maximal into the most respectable forklift brand.

## Current products consist of:

### M series:

- 1.5-32T/3000-64,000LB capacity diesel forklifts.
- 1.5-7T/3000-14,000LB capacity gasoline/LPG forklifts.
- 4.5T/8000-10,000LB capacity 4-wheel electric forklifts.
- 1.6-2T/3200-4000LB capacity 3-wheel electric forklifts.
- 0.7-1.5T/1400-3000LB capacity VNA truck.
- 1.6T/3200LB capacity Rear drive 3-wheel electric forklifts.
- 2.5T/4000-5000LB capacity dual-drive 4-wheel electric forklifts.
- 2.5T/4000-5000LB capacity cushion tyre forklifts.
- 1.3-3T/2600-6000LB capacity Omni-Directional electric forklifts.

### A series:

- 2.5-3.5T/4000-7000LB capacity diesel and gasoline/LPG forklifts.

1.5-3.5T/3000-7000LB capacity 4-wheel electric forklifts.

1.6-2.5T/3200-5000LB capacity electric reach truck.

### Rough Terrain:

1.8-3.5T/3600-7000LB capacity compact 4WD rough terrain forklifts.

2.5-3.5T/5000-7000LB capacity 4WD rough terrain forklifts.

1.8-5.0T/3600-10,000LB capacity 2WD rough terrain forklifts.

### Port Machinery:

9T/18,000LB capacity empty container handler.

45T/90,000LB capacity reach stacker.

### Side Loader Forklift:

3.5T-4.5T/7000-9900LB capacity side loader forklifts.

## A series 4-wheel electric forklift

Ranges from 1.5-3.5t, with ZAPI ACE2 controller of horizontally layout, integrated transmission and axle, L-type pump motor. A series model design concept is "Engineering for driver", with more safety, more comfort, and every small detail carefully designed prepared for the driver.



Classification of After-sales Service

## A series reach truck

Can be provided with stand operation model and sit operation model, load capacity ranges from 1.6-2.5t, not only enjoys excellent performance, but also has economical price. It is equipped with AC system, drive motor 6.5kw and lifting motor 11kw, hydraulic parking brake, electronic steering, compact structure, small size, small turning radius and excellent maneuvering performance,



24-hour fast reply on trucks and parts claims

## M series 3-wheel electric forklift

Ranges from 1.6-2t, is a series of products developed and manufactured to satisfy the market demands, this 3-wheel type design is the perfect machine for dock operations loading & unloading trucks & trailers. The compact and streamlined body can maneuver in close spaces and narrow aisle applications eliminating the need for the more expensive reach machines.

## M series rear drive 3-wheel electric forklift

Designed load capacity 1.6t, is a type of super economic forklift, with ZAPI ACE2 Controller, rear drive with one pc of driving motor, battery capacity 48V425AH, one mini rear steering wheel makes the turning radius smaller, with cost-effective, stable, working flexibility, high interchangeability etc. high performance, popular welcomed by market at home and abroad.

## Classification of After-sales Service

Classification of After-sales Service classifies customer claims into 3 classes, Warranty 1(W1), Warranty 2(W2), Warranty 3(W3). Different claim class has different after-sales procedures which aims to increase service quality.



## A SERIES 1.5-3.5t 4-wheel electric forklift/Li-Ion battery forklift

Specification	1	Model	FBA15-JZ	FBA18-JZ	FBA20-JZ	FBA25-JZ	FBA30-JZ	FBA35-JZ
	2	Rated capacity	kg	1500	1800	2000	2500	3000
3	Load centre	mm	500					
4	Lifting height	mm	3000					
5	Free lifting height	mm	135		140		165	
6	Fork size	T×W×L	35×100×920		40×122×1070		45×125×1070	
7	Tilting angle	F/R (α°/β°)	5/10					
Dimensions	8	Overall Dimension	Length (to forkface)	2073	2118	2286.5	2548	2639
	9		Width	1120		1285	1285	1365
	10		Height when mast lowered	2000		2015	2045	2120
	11		Height when mast extended	3980		3990	4100	4140
	12	Height to safeguard	2135		2152	2152	2138	
13	Turning radius	Min.	1965		2080	2349	2405	
14	Front overhang/rear overhang	mm	410/317		454/390	475/402	495.5/453.5	
15	Tread	F/R	955/920		1058/960	1065/980	1124/1010	
16	Ground clearance	Min.	105		95	110	83	
17	Wheelbase	mm	1380		1485	1670	1690	
18	Fork spread	Min./Max.	250/890		250/1000	250/1060		
19	Working aisle width with pallet(Ast)*	1000×1200 crossways	3541		3732	4025	4101	
20		800×1200 lengthways	3741		3932	4225	4301	
Performance	21	Speed	Travel(Laden)	15		15	15	
	22		Travel(Unladen)	16		16	16	
	23		lifting (laden/unladen)	290/440		280/440	280/400	280/384
	24		lowering (laden/unladen)	410/410		470/430	400/315	
25	Gradeability	Laden	15		15	15		
26		Unladen	15		15	15		
27	Service weight	Include battery box	2950	3230	3930	4100	4750	5253
28	Tyre	Front×2	6.00-9 10PR		23×9-10 16PR	23×9-10 16PR	23×10-12	
29		Rear×2	5.00-8 8PR		18×7-8-14PR	18×7-8-14PR	200/50-10	
Driven	30	Motor	Driven motor	K6.5		K8.5	K11.5	
	31		Pump motor	K8.6		K11	K15	
	32	Battery	Standard(Optional)	48/420		48/600	80/500	
	33	Controller	Type	AC	AC	AC	AC	AC
	34		Manufacturer	ZAPI	ZAPI	ZAPI	ZAPI	ZAPI
35	Operating pressure for attachment	Mpa	14.5		17.5			

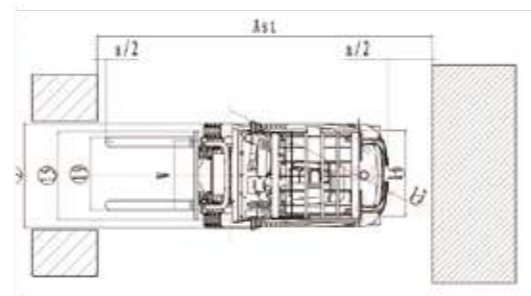
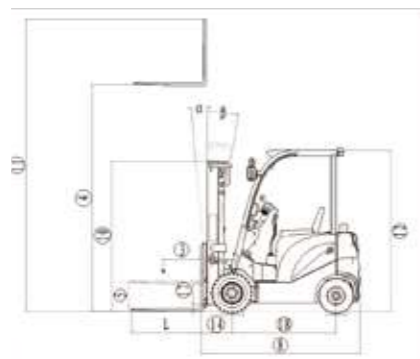

## A SERIES 1.5-1.8t forklift mast

Type	Model	Max. fork height	Overall height						Free lift		Front Overhang		Tilt range		Capacity	
			Lowered		Extended				Without backrest	with backrest	1.5t	1.8t	FWD	BWD	load capacity at 500mm	
			1.5t	1.8t	Without backrest		With backrest								Single tyre	
					mm	mm	mm	mm	mm	mm	mm	mm	Deg	Deg	kg	kg
wide view 2-stage mast	M300	3000	1990	1990	3513	3513	3984	3984	135	135	410	410	5	10	1500	1800
	M330	3300	2140	2140	3813	3813	4284	4284	135	135	410	410	5	10	1500	1800
	M350	3500	2240	2240	4013	4013	4484	4484	135	135	410	410	5	10	1500	1800
	M370	3700	2340	2340	4213	4213	4684	4684	135	135	410	410	5	10	1460	1760
	M400	4000	2540	2540	4513	4513	4984	4984	135	135	410	410	5	10	1400	1700
	M450	4500	2790	2790	5013	5013	5484	5484	135	135	410	410	5	6	1300	1500
full free 2-stage mast	M500	5000	3040	3040	5513	5513	5984	5984	135	135	410	410	5	6	1000	1100
	M550	5500	3340	3340	6013	6013	6484	6484	135	135	410	410	3	6	800	1000
	M600	6000	3590	3590	6513	6513	6984	6984	135	135	410	410	3	6	500	600
	FM300	3000	1990	1990	3513	3513	3984	3984	1486	1015	435	435	5	10	1500	1800
Full free 3-stage mast	FM330	3300	2140	2140	3813	3813	4284	4284	1636	1165	435	435	5	10	1500	1800
	FM350	3500	2240	2240	4013	4013	4484	4484	1736	1265	435	435	5	10	1500	1800
	FM370	3700	2340	2340	4213	4213	4684	4684	1836	1365	435	435	5	10	1410	1710
	TFM435	4350	1990	1990	4863	4863	5334	5334	1466	995	435	435	5	6	1250	1500
Full free 3-stage mast	TFM450	4500	2040	2040	5013	5013	5484	5484	1516	1045	435	435	5	6	1200	1400
	TFM480	4800	2140	2140	5313	5313	5784	5784	1616	1145	435	435	5	6	1100	1200
	TFM500	5000	2240	2240	5513	5513	5984	5984	1716	1245	435	435	5	6	950	1050
	TFM550	5500	2405	2405	6013	6013	6484	6484	1886	1415	435	435	3	6	750	850
	TFM600	6000	2590	2590	6513	6513	6984	6984	2066	1595	435	435	3	6	450	550
TFM650	6500	2805	2805	7013	7013	7484	7484	2281	1810	435	435	3	6	250	300	

## A SERIES 2-2.5t forklift mast

Type	Model	Max. fork height	Overall height						Free lift		Front Overhang		Tilt range		Capacity	
			Lowered		Extended				Without backrest	with backrest	2t	2.5t	FWD	BWD	load capacity at 500mm	
			2t	2.5t	Without backrest		With backrest								Single tyre	
					mm	mm	mm	mm	mm	mm	mm	mm	Deg	Deg	kg	kg
wide view 2-stage mast	M300	3000	2030	2030	3615	3615	4015	4015	140	140	454	454	5	10	2000	2500
	M330	3300	2180	2180	3915	3915	4315	4315	140	140	454	454	5	10	2000	2500
	M350	3500	2280	2280	4115	4115	4515	4515	140	140	454	454	5	10	2000	2500
	M370	3700	2380	2380	4315	4315	4715	4715	140	140	454	454	5	10	2000	2500
	M400	4000	2580	2580	4615	4615	5015	5015	140	140	454	454	5	10	2000	2500
	M450	4500	2830	2830	5115	5115	5515	5515	140	140	454	454	5	6	1600	2100
full free 2-stage mast	M500	5000	3080	3080	5615	5615	6015	6015	140	140	454	454	5	6	1200	1600
	M550	5500	3380	3380	6115	6115	6515	6515	140	140	454	454	3	6	950	1200
	M600	6000	3630	3630	6615	6615	7015	7015	140	140	454	454	3	6	800	900
	FM300	3000	2030	2030	3615	3615	4015	4015	1385	985	477	477	5	10	2000	2500
Full free 3-stage mast	FM330	3300	2180	2180	3915	3915	4315	4315	1535	1135	477	477	5	10	2000	2500
	FM350	3500	2280	2280	4115	4115	4515	4515	1635	1235	477	477	5	10	2000	2500
	FM370	3700	2380	2380	4315	4315	4715	4715	1735	1335	477	477	5	6	2000	2500
	TFM435	4350	2040	2040	4965	4965	5365	5365	1390	990	490	490	5	6	1750	2200
Full free 3-stage mast	TFM450	4500	2090	2090	5115	5115	5515	5515	1440	1040	490	490	5	6	1550	2000
	TFM480	4800	2190	2190	5415	5415	5815	5815	1540	1140	490	490	5	6	1250	1700
	TFM500	5000	2290	2290	5615	5615	6015	6015	1640	1240	490	490	5	6	1100	1500
	TFM550	5500	2455	2455	6115	6115	6515	6515	1765	1400	490	490	3	6	850	1100
	TFM600	6000	2640	2640	6615	6615	7015	7015	1990	1590	490	490	3	6	700	800
TFM650	6500	2855	2855	7115	7115	7515	7515	2205	1805	490	490	3	6	400	500	

Li-Ion battery is available for 4-wheel electric forklift

Main advantages:

	<b>Compact body</b> energy density more than 120W · h/kg		<b>Operating temperature</b> Charge: 0~45 °C Discharge: -20~60 °C
	<b>Long service life</b> >2500 times (80% remaining capacity), the service life more than 5 years or 10000 hours		<b>5 years guarantee</b>
	<b>High charge efficiency</b> >97%		<b>Impact of environment</b> zero pollution
	<b>Fast charging</b> 2-4hours quick charge, no memory effect.		<b>Control system</b> With BMS management system, it can monitor the current, voltage, temperature, SOC and other conditions of each battery pack. With self-protection.
	<b>High safety and reliability</b>		<b>Maintenance free</b>

**A SERIES 3-3.5t forklift mast**

Type	Model	Max. fork height mm	Overall height						Free lift				Front Overhang		Tilt range		Capacity	
			Lowered		Extended				Without backrest		with backrest		3t	3.5t	FWD	BWD	load capacity at 500mm	
			3t	3.5t	Without backrest		With backrest		3t	3.5t	3t	3.5t					Single tyre	
					mm	mm	mm	mm					mm	mm	mm	mm	kg	kg
wide view 2-stage mast	M300	3000	2045	2120	3670	3740	4140	4140	165	170	165	170	475	495	5	10	3000	3500
	M330	3300	2195	2270	3970	4040	4440	4440	165	170	165	170	475	495	5	10	3000	3500
	M350	3500	2295	2370	4170	4240	4640	4640	165	170	165	170	475	495	5	10	3000	3500
	M370	3700	2395	2470	4370	4440	4840	4840	165	170	165	170	475	495	5	10	3000	3500
	M400	4000	2595	2670	4670	4740	5140	5140	165	170	165	170	475	495	5	10	2850	3300
	M450	4500	2845	2920	5170	5240	5640	5640	165	170	165	170	475	495	5	6	2550	2900
	M500	5000	3095	3170	5670	5740	6140	6140	165	170	165	170	475	495	5	6	2100	2400
	M550	5500	3395	3470	6170	6240	6640	6640	165	170	165	170	475	495	3	6	1700	1800
full free 2-stage mast	FM300	3000	2045	2120	3685	3725	4140	4140	1390	1415	935	1000	490	505	5	10	3000	3500
	FM330	3300	2195	2270	3985	4025	4440	4440	1540	1565	1085	1150	490	505	5	10	3000	3500
	FM350	3500	2295	2370	4185	4225	4640	4640	1640	1665	1185	1250	490	505	5	10	3000	3500
	FM370	3700	2395	2470	4385	4425	4840	4840	1740	1765	1285	1350	490	505	5	10	3000	3500
Full free 3-stage mast	TFM435	4350	2045	2120	5075	5160	5490	5490	1340	1330	925	925	500	522	5	6	2800	3100
	TFM450	4500	2095	2170	5225	5310	5640	5640	1390	1380	975	975	500	522	5	6	2500	2800
	TFM480	4800	2195	2270	5525	5610	5940	5940	1490	1480	1075	1075	500	522	5	6	2250	2500
	TFM500	5000	2295	2370	5725	5810	6140	6140	1590	1580	1175	1175	500	522	5	6	2050	2250
	TFM550	5500	2460	2535	6225	6310	6640	6640	1745	1735	1330	1405	500	522	3	6	1600	1700
	TFM600	6000	2645	2720	6725	6810	7140	7140	1940	1930	1525	1525	500	522	3	6	1200	1300
TFM650	6500	2860	2935	7225	7310	7640	7640	2155	2145	1740	1740	500	522	3	6	700	800	

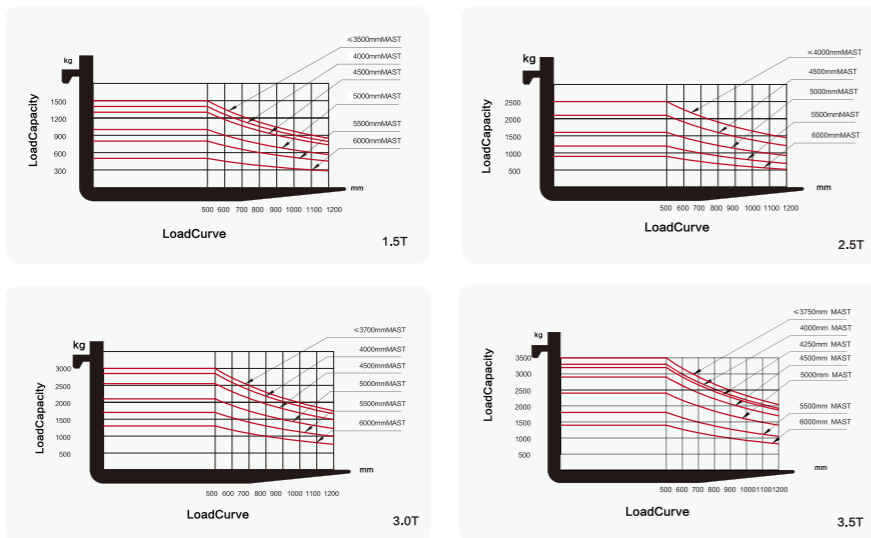

**A SERIES** 1.6-2.5t reach truck (Sit-on)

1	Model	FBREA16-JI			FBREA20-JI			FBREA25-JI				
		Electirc										
2	Power	Electirc										
3	Operator type	Sit-on										
Specification	4	Rated load capacity	Q(kg)	1600	2000	2500						
	5	Rated lift height	h3(mm)	3000	3000	3000						
	6	Load centre	C(mm)	600	600	600						
	7	Fork carriage tilt (Forward/Backward)	$\alpha/\beta$ (deg)	2°/4°	2°/4°	2°/4°						
	8	Travel speed (Laden/Unladen)	(km/h)	10.0/11.0	10.0/11.0	10.0/10.5						
	9	Lifting speed(Laden)	(mm/s)	290	280	260						
	10	Max. gradeability(Laden)	(%)	10	10	10						
	11	Min. turning radius	Wa(mm)	1690	1750	1850						
	12	Reach distance	X(mm)	570	660	660						
	13	Wheelbase	Y(mm)	1440	1500	1600						
	14	Service brake		Hyd	Hyd	Hyd						
	Dimensions	15	Overall length	l1(mm)	2381	2381	2480					
		16	Main body length	l7(mm)	1852	1942	2042					
		17	Rear body length	l2(mm)	1311	1311	1410					
18		Overall width	b1(mm)	1270	1270	1270						
19		Height of mast,lowered	h1(mm)	2090	2090	2130						
20		Free lift height	h2(mm)	330	330	330						
21		Height of mast,extended	h4(mm)	3895	3895	3875						
22		Height of overhead guard	h5(mm)	2100	2100	2100						
23		Fork dimensions(T×W×L)	(mm)	40×122×1070	40×122×1070	40×122×1070						
24		Fork regulating range(Min/Max)	(mm)	270/714	270/714	270/714						
25		Min. ground clearance	h6(mm)	85	85	85						
Tyre	26	Min. aisle width with pallet (1200L×1000W)	Ast1(mm)	2750	2770	2870						
	27	Min. aisle width with pallet (800L×1200W)	Ast2(mm)	2800	2810	2910						
	28	Service weight	(kg)	2860	3070	3520						
	29	Drive motor	(Kw)	6.5	6.5	6.5						
	30	Lift motor	(Kw)	11	11	11						
	31	Battery:Voltage/capacity (5h)standard (option)	(V/Ah)	48/450	48/450	48/600						
	32	Tyres		Polyurethane Solid tyre								
	33	Size of front tyre	(mm)	∅ 285×108		∅ 343×108						
	34	Size of driven tyre	(mm)	∅ 343×140								
	35	Size of balancing tyre	(mm)	1132								
Other	36	Turning system	Electirc									
	37	Speed control system	Inmotion									

**A SERIES** 1.6-2.5t reach truck mast (Sit-on)

Type	Model	Max. fork height	Mast height									Free lift height						Capacity						
			Overall height (mm) -lowered			Lifting height						without bracket			with bracket			Front overhang			Load center (600mm)			
			1.6T	2.0T	2.5T	Without backrest			With backrest			1.6T	2.0T	2.5T	1.6T	2.0T	2.5T	1.6T	2.0T	2.5T	1.6T	2.0T	2.5T	
			mm	mm	mm	mm	mm	mm	mm	mm	mm	mm	mm	mm	mm	mm	mm	mm	mm	mm	mm	mm	mm	mm
2-stage	RM300	3000	2090	2090	2130	3615	3615	3595	3895	3895	3875	330	330	330	330	330	330	191	221	220	1600	2000	2500	
	RM360	3600	2390	2390	2430	4205	4205	4195	4485	4485	4475	330	330	330	330	330	330	191	221	220	1600	2000	2500	
	RM380	3800	2490	2490	2530	4405	4405	4395	4685	4685	4675	330	330	330	330	330	330	191	221	220	1600	2000	2500	
	RM400	4000	2640	2640	2680	4605	4605	4595	4885	4885	4875	330	330	330	330	330	330	191	221	220	1600	2000	2500	
	RM420	4200	2740	2740	2780	4805	4805	4795	5085	5085	5075	330	330	330	330	330	330	191	221	220	1600	2000	2500	
	RM450	4500	2890	2890	2930	5105	5105	5095	5385	5385	5375	330	330	330	330	330	330	191	221	220	1600	2000	2500	
	RM480	4800	3040	3040	3080	5405	5405	5395	5685	5685	5675	330	330	330	330	330	330	191	221	220	1600	2000	2500	
	RM500	5000	3140	3140	3180	5605	5605	5595	5885	5885	5875	330	330	330	330	330	330	191	221	220	1600	2000	2500	
	RM550	5500	3440	3440	3480	6105	6105	6095	6385	6385	6375	330	330	330	330	330	330	191	221	220	1600	2000	2250	
	RM600	6000	3690	3690	3730	6605	6605	6595	6885	6885	6875	330	330	330	330	330	330	191	221	220	1500	1800	2000	
3-stage	RTFM400	4000	1915	1915	1950	4605	4605	4675	4885	4885	4880	1355	1355	1270	1030	1030	1060	191	221	220	1600	2000	2500	
	RTFM420	4200	1980	1980	2015	4805	4805	4870	5085	5085	5075	1425	1425	1335	1095	1095	1125	191	221	220	1600	2000	2500	
	RTFM450	4500	2080	2080	2115	5105	5105	5170	5385	5385	5375	1520	1520	1435	1195	1195	1230	191	221	220	1600	2000	2500	
	RTFM480	4800	2180	2180	2215	5405	5405	5470	5685	5685	5675	1625	1625	1535	1295	1295	1330	191	221	220	1600	2000	2500	
	RTFM500	5000	2300	2300	2315	5605	5605	5670	5885	5885	5875	1740	1740	1635	1410	1410	1430	191	221	220	1600	2000	2500	
	RTFM520	5200	2365	2365	2385	5805	5805	5875	6085	6085	6080	1805	1805	1705	1480	1480	1495	191	221	220	1600	2000	2300	
	RTFM560	5600	2500	2500	2515	6205	6205	6270	6485	6485	6475	1940	1940	1835	1610	1610	1630	191	221	220	1600	2000	2200	
	RTFM600	6000	2630	2630	2650	6605	6605	6675	6885	6885	6880	2075	2075	1970	1745	1745	1760	191	221	220	1500	1850	2000	
	RTFM620	6200	2700	2700	2715	6805	6805	6870	7085	7085	7075	2140	2140	2035	1810	1810	1830	191	221	220	1450	1800	1950	
	RTFM660	6600	2880	2880	2900	7205	7205	7280	7485	7485	7485	2280	2280	2220	1995	1995	2015	191	221	220	1400	1700	1900	
	RTFM700	7000	3015	3015	3035	7605	7605	7680	7885	7885	7885	2415	2415	2355	2130	2130	2145	191	221	220	1100	1400	1800	
	RTFM720	7200	3080	3080	3100	7805	7805	7880	8085	8085	8085	2480	2480	2420	2195	2195	2215	191	221	220	1050	1300	1600	
	RTFM750	7500	3180	3180	3200	8105	8105	8180	8385	8385	8385	2580	2580	2520	2295	2295	2315	191	221	220	1000	1200	1500	
	RTFM800	8000	3350	3350	3370	8605	8605	8680	8885	8885	8885	2750	2750	2685	2460	2460	2480	191	221	220	800	1000	1300	
	RTFM820	8200	/	3435	3435	/	8880	8880	/	9085	9085	/	2755	2755	/	2545	2545	/	221	220	/	950	1250	
	RTFM850	8500	/	3535	3535	/	9180	9180	/	9385	9385	/	2855	2855	/	2645	2645	/	221	220	/	900	1200	
RTFM900	9000	/	3700	3700	/	9680	9680	/	9885	9885	/	3020	3020	/	2815	2815	/	221	220	/	800	1100		
RTFM920	9200	/	3770	3770	/	9880	9880	/	10085	10085	/	3085	3085	/	2880	2880	/	221	220	/	700	1000		
RTFM950	9500	/	3870	3870	/	10180	10180	/	10385	10385	/	3185	3185	/	2980	2980	/	221	220	/	600	950		
RTFM1000	10000	/	4035	4035	/	10680	10680	/	10885	10885	/	3355	3355	/	3150	3150	/	221	220	/	500	800		

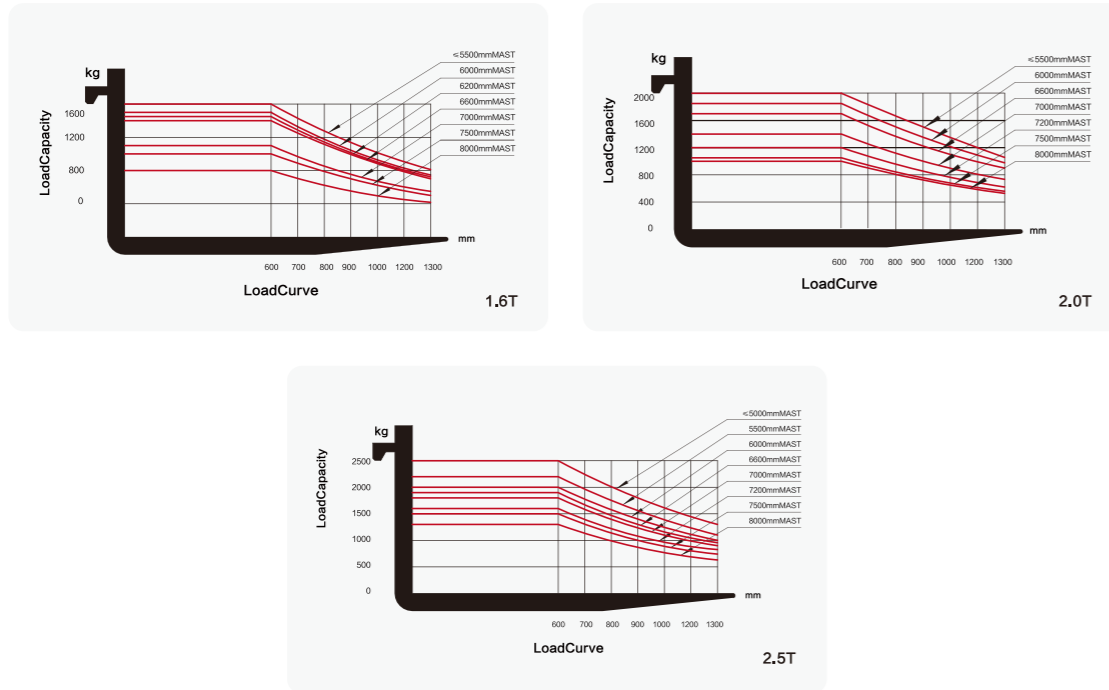

### A SERIES 1.5-2.5t reach truck (Stand-on)

Specification	1	Model	FBRA15-JI	FBRA20-JI	FBRA25-JI		
	2	Power	Electric				
	3	Operation	Stand-on				
Specification	4	Rated load capacity	Q(kg)	1500	2000	2500	
	5	Rated lift height	h3(mm)	3000	3000	3000	
	6	Load centre	C(mm)	500	500	500	
	7	Fork carriage tilt (Forward/Backward)	$\alpha/\beta$ (deg)	2° /4°	2° /4°	2° /4°	
	8	Travel speed (Laden/Unladen)	(km/h)	10.0/11.0	10.0/11.0	10.0/10.5	
	9	Lifting speed(Laden)	(mm/s)	290/420	280/410	260/400	
	10	Max. gradeability(Laden)	(%)	10	10	10	
	11	Min. turning radius	Wa(mm)	1580	1755	1930	
	12	Reach distance	X(mm)	530	675	757	
	13	Wheelbase	Y(mm)	1322	1497	1672	
	14	Service brake		Electric	Electric	Electric	
	Dimensions	15	Overall length	l1(mm)	2290	2290	2375
		16	Main body length	l7(mm)	1720	1895	2070
		17	Rear body length	l2(mm)	1220	1250	1345
18		Overall width	b1(mm)	1090	1200	1200	
19		Height of mast,lowered	h1(mm)	2090	2090	2130	
20		Free lift height	h2(mm)	330	330	330	
21		Height of mast,extended	h4(mm)	3895	3895	3875	
22		Height of overhead guard	h5(mm)	2270	2270	2270	
23		Fork dimensions(T×W×L)	(mm)	40×122×1070	40×122×1070	40×122×1070	
24		Fork regulating range(Min/Max)	(mm)	270/714	270/714	270/714	
25		Min. ground clearance	h6(mm)	85	85	85	
26		Min. aisle width with pallet (1200L×1000W)	Ast1(mm)	2655	2770	2870	
27		Min. aisle width with pallet (800L×1200W)	Ast2(mm)	2710	2810	2910	
28		Service weight	(kg)	2500	3070	3520	
Tyre	29	Drive motor	(Kw)	6.5	6.5	6.5	
	30	Lift motor	(Kw)	11	11	11	
	31	Battery:Voltage/capacity (5h)standard (option)	(V/Ah)	48/340	48/340	48/425	
	32	Tyres		Polyurethane Solid tyre			
	33	Size of front tyre	(mm)	φ 250 × 85	φ 250 × 110	φ 250 × 110	
	34	Size of driven tyre	(mm)	φ 343 × 140	φ 343 × 140	φ 343 × 140	
	35	Tread , Front	(mm)	1004	1077	1077	
	36	Tread , Rear			647		
Other	37	Turning system		Electric			
	38	Speed control system		Inmotion			

**A SERIES** 1.5-2.5t reach truck mast (Stand-on)

Type	Model	Max. fork height mm	Overall height									Free lift height						Capacity					
			Lowered			Extended						without bracket			with bracket			Front overhang			Load center (500mm)		
			1.5T	2.0T	2.5T	Without backrest			With backrest			1.5T	2.0T	2.5T	1.5T	2.0T	2.5T	1.5T	2.0T	2.5T	1.5T	2.0T	2.5T
			mm	mm	mm	mm	mm	mm	mm	mm	mm	mm	mm	mm	mm	mm	mm	mm	mm	mm	mm	mm	mm
2-stage	RM300	3000	2090	2090	2130	3615	3615	3595	3895	3895	3875	330	330	330	330	330	330	191	221	220	1500	2000	2500
	RM360	3600	2390	2390	2430	4205	4205	4195	4485	4485	4475	330	330	330	330	330	330	191	221	220	1500	2000	2500
	RM380	3800	2490	2490	2530	4405	4405	4395	4685	4685	4675	330	330	330	330	330	330	191	221	220	1500	2000	2500
	RM400	4000	2640	2640	2680	4605	4605	4595	4885	4885	4875	330	330	330	330	330	330	191	221	220	1500	2000	2500
	RM420	4200	2740	2740	2780	4805	4805	4795	5085	5085	5075	330	330	330	330	330	330	191	221	220	1500	2000	2400
	RM450	4500	2890	2890	2930	5105	5105	5095	5385	5385	5375	330	330	330	330	330	330	191	221	220	1400	1900	2200
	RM480	4800	3040	3040	3080	5405	5405	5395	5685	5685	5675	330	330	330	330	330	330	191	221	220	1350	1800	2100
	RM500	5000	3140	3140	3180	5605	5605	5595	5885	5885	5875	330	330	330	330	330	330	191	221	220	1300	1700	2000
	RM550	5500	3440	3440	3480	6105	6105	6095	6385	6385	6375	330	330	330	330	330	330	191	221	220	1100	1550	1800
RM600	6000	3690	3690	3730	6605	6605	6595	6885	6885	6875	330	330	330	330	330	330	191	221	220	1000	1400	1700	
3-stage	RTFM400	4000	1915	1915	1950	4605	4605	4675	4885	4885	4880	1355	1355	1270	1030	1030	1060	191	221	220	1500	2000	2500
	RTFM420	4200	1980	1980	2015	4805	4805	4870	5085	5085	5075	1425	1425	1335	1095	1095	1125	191	221	220	1500	2000	2400
	RTFM450	4500	2080	2080	2115	5105	5105	5170	5385	5385	5375	1520	1520	1435	1195	1195	1230	191	221	220	1400	1900	2200
	RTFM480	4800	2180	2180	2215	5405	5405	5470	5685	5685	5675	1625	1625	1535	1295	1295	1330	191	221	220	1350	1800	2100
	RTFM500	5000	2300	2300	2315	5605	5605	5670	5885	5885	5875	1740	1740	1635	1410	1410	1430	191	221	220	1300	1700	2000
	RTFM520	5200	2365	2365	2385	5805	5805	5875	6085	6085	6080	1805	1805	1705	1480	1480	1495	191	221	220	1200	1600	1900
	RTFM560	5600	2500	2500	2515	6205	6205	6270	6485	6485	6475	1940	1940	1835	1610	1610	1630	191	221	220	1100	1550	1800
	RTFM600	6000	2630	2630	2650	6605	6605	6675	6885	6885	6880	2075	2075	1970	1745	1745	1760	191	221	220	1000	1400	1700
	RTFM620	6200	2700	2700	2715	6805	6805	6870	7085	7085	7075	2140	2140	2035	1810	1810	1830	191	221	220	950	1350	1650
	RTFM660	6600	2880	2880	2900	7205	7205	7280	7485	7485	7485	2280	2280	2220	1995	1995	2015	191	221	220	900	1200	1600
	RTFM700	7000	3015	3015	3035	7605	7605	7680	7885	7885	7885	2415	2415	2355	2130	2130	2145	191	221	220	800	1100	1500
	RTFM720	7200	3080	3080	3100	7805	7805	7880	8085	8085	8085	2480	2480	2420	2195	2195	2215	191	221	220	750	1050	1450
	RTFM750	7500	3180	3180	3200	8105	8105	8180	8385	8385	8385	2580	2580	2520	2295	2295	2315	191	221	220	700	1000	1350
RTFM800	8000	3350	3350	3370	8605	8605	8680	8885	8885	8885	2750	2750	2685	2460	2460	2480	191	221	220	600	900	1200	

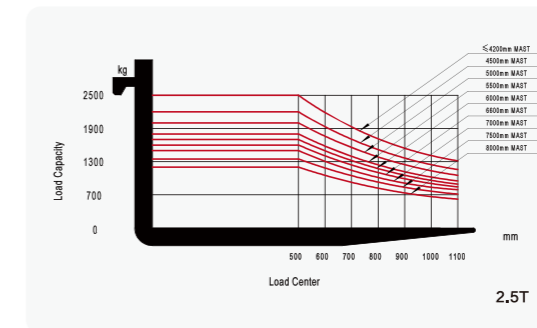
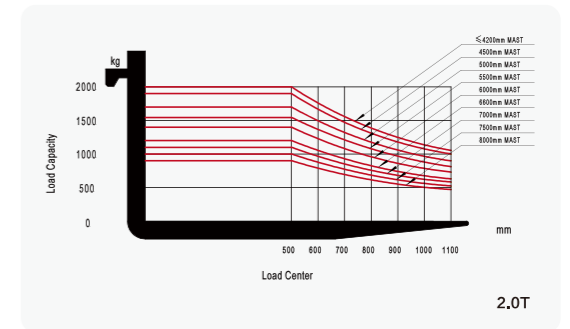
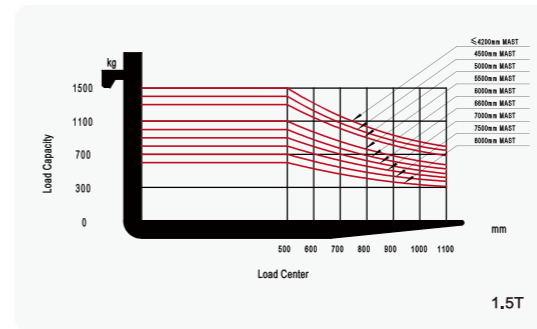



## M SERIES 1.6-2.0t 3-wheel electric forklift

Specification	1	Model		FB16S-MJZ	FB18S-MJZ	FB20S-MJZ	
	2	Rated capacity	kg		1600	1800	2000
3	Load centre	mm		500	500	500	
4	Lifting height	mm		3000	3000	3000	
5	Free lifting height	mm		0	0	0	
6	Fork size	T×W×L	mm	35×100×920	35×100×920	35×100×920	
	7	Tilting angle	F/R (α°/β°)	Deg	6.5°/6.5°	6.5°/6.5°	6.5°/6.5°
Dimensions	8	Overall Dimension	Length (to forkface)	mm	1979	1979	2094
			Width	mm	1070	1070	1140
			Height when mast lowered	mm	1975	1975	1975
			Height when mast extended	mm	4010	4010	4010
	12	Height to safeguard	mm	1971	1971	2011	
	13	Turning radius	Min.	mm	1643	1643	1758
	14	Front overhang		mm	371	371	371
	15	Tread	F/R	mm	924/186	924/186	942/186
Performance	16	Ground clearance	Min.	mm	90	90	90
	17	Wheelbase		mm	1400	1400	1515
	18	Fork spread	Min./Max.	mm	200/890	200/890	200/890
	19	Working aisle width with pallet(Ast)*	1000×1200 crossways	mm	3340	3340	3445
	20		800×1200 lengthways	mm	3464	3464	3579
Driven	21	Speed	Travel(Laden)	km/h	13	13	13
			Travel(Unladen)	km/h	13	13	13
			Lifting(Laden)	mm/s	290	280	255
			Lifting(Unladen)	mm/s	445	435	435
	25	Gradeability	Laden	%	15	15	15
			Unladen	%	15	15	15
	27	Service weight	Include battery box	kg	3080	3140	3430
28	Tyre	Front×2		18×7-8	18×7-8	200/50-10	
		Rear×2		15×4 <sup>1/2</sup> -8	15×4 <sup>1/2</sup> -8	15×4 <sup>1/2</sup> -8	
29	Motor	Driven motor	kw	4×2	4×2	4×2	
		Pump motor	kw	9.2	11	11	
	32	Battery	Standard(Optional)	V/Ah	48/500	48/500	48/620
	33	Controller	Type		AC	AC	AC
			Manufacturer		ZAPI	ZAPI	ZAPI
35	Operating pressure for attachment	Mpa		14.5	14.5	17.5	

## M SERIES 1.6-2.0t 3-wheel electric forklift mast

Type	Model	Max. fork height	Overall height				Free lift		Front Overhang	Tilt range		Capacity		
			Lowered	Extended		Without backrest	with backrest	FWD		BWD	load capacity at 500mm			
				Without backrest	With backrest						1.6t	1.8t	2.0t	
		mm	mm	mm	mm	mm	mm	mm	Deg	Deg	kg	kg	kg	
2-stage mast	BM250	2500	1725	3010	3480	0	0	376	6.5	6.5	1600	1800	2000	
	BM270	2700	1825	3210	3680	0	0	376	6.5	6.5	1600	1800	2000	
	BM300	3000	1975	3490	4010	0	0	376	6.5	6.5	1600	1800	2000	
	BM330	3300	2125	3790	4310	0	0	376	6.5	6.5	1600	1800	2000	
	BM350	3500	2225	3990	4510	0	0	376	6.5	6.5	1600	1800	2000	
	BM370	3700	2325	4190	4710	0	0	376	6.5	6.5	1600	1800	2000	
	BM400	4000	2525	4490	5010	0	0	376	3.5	5	1600	1800	2000	
	BM425	4250	2650	4760	5280	0	0	376	3.5	5	1500	1700	1900	
	BM450	4500	2775	4990	5510	0	0	376	3.5	5	1400	1600	1800	
ffull free 2-stage mast	BFM250	2500	1725	3010	3465	1200	760	376	6.5	6.5	1600	1800	2000	
	BFM270	2700	1825	3210	3665	1300	860	376	6.5	6.5	1600	1800	2000	
	BFM300	3000	1975	3490	4010	1450	1010	376	6.5	6.5	1600	1800	2000	
	BFM330	3300	2125	3790	4310	1600	1160	376	6.5	6.5	1600	1800	2000	
	BFM350	3500	2225	3990	4510	1700	1260	376	6.5	6.5	1600	1800	2000	
	BFM370	3700	2325	4190	4710	1800	1360	376	6.5	6.5	1600	1800	2000	
	BFM400	4000	2525	4490	5010	2000	1560	376	3.5	5	1600	1800	2000	
Full free 3-stage mast	BTFM435	4350	1975	4860	5360	1425	995	376	3.5	5	1500	1700	1900	
	BTFM450	4500	2025	4990	5510	1475	1045	376	3.5	5	1400	1600	1800	
	BTFM480	4800	2125	5290	5810	1575	1145	376	3.5	5	1300	1500	1650	
	BTFM500	5000	2225	5490	6010	1675	1245	376	3.5	5	1250	1450	1500	
	BTFM550	5500	2390	5990	6510	1840	1410	376	3.5	5	1150	1200	1300	
	BTFM600	6000	2575	6490	7010	2025	1595	376	3.5	5	1050	1100	1200	
BTFM650	6500	2790	6990	7510	2205	1775	376	3.5	5	900	950	1000		

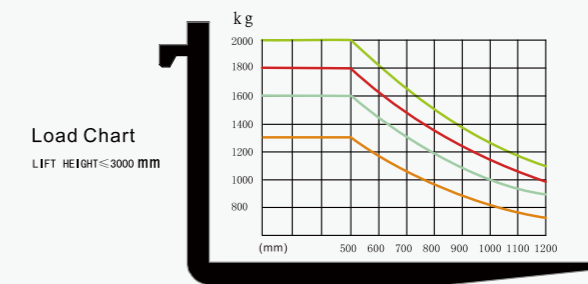

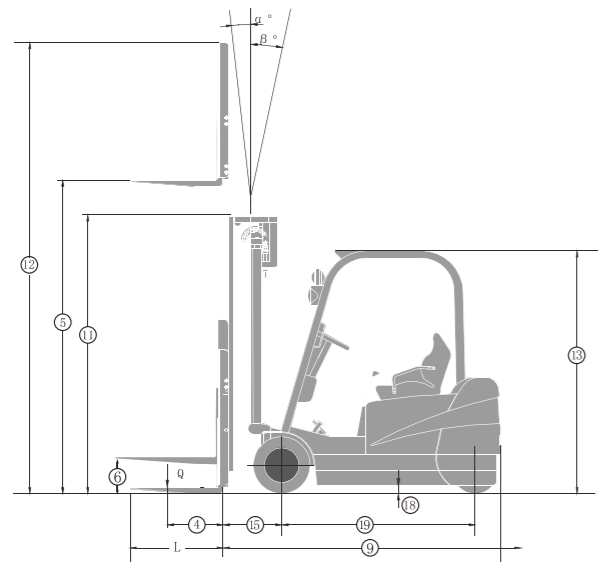

a=200 mm safety clearance  
 $AST = a + (14) + (15) + \sqrt{W^2 + (B/2)^2}$

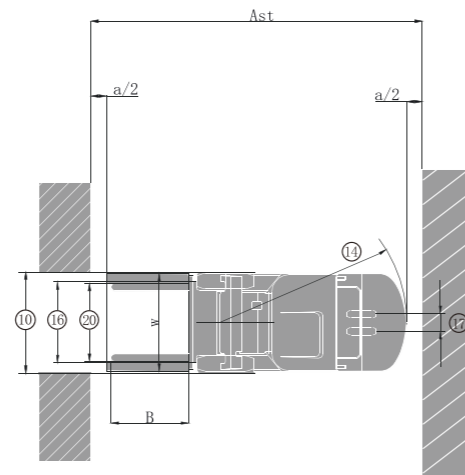

### M SERIES 1.6t rear drive 3-wheel electric forklift

Specification	1	Model		FB16S-MHJZ	
	2	Power		Electric	
	3	Rated capacity	kg	1600	
	4	Load centre	mm	500	
	5	Lifting height	mm	3000	
	6	Free lifting height	mm	0	
	7	Fork size	T×W×L	mm	920×100×35
Dimensions	8	Tilting angle	F/R (α°/β°)	Deg	3°/6°
	9	Overall Dimension	Length (to forkface)	mm	1919
	10		Width	mm	1078
	11		Height when mast lowered	mm	1975
	12		Height when mast extended	mm	4010
	13		Height to safeguard	mm	1952
	14	Turning radius	mm	1544	
	15	Front overhang	mm	376	
	16	Tread	F/R	mm	930/0
	17	Ground clearance Min.	mm	85	
	18	Wheelbase	mm	1245	
	Performance	19	Fork spread	Min./Max.	mm
20		Working aisle width with pallet(Ast)*	1000×1200 crossways	mm	3245
21			800×1200 lengthways	mm	3370
22		Speed	Travel(Laden)	km/h	12
23			Travel(Unladen)	km/h	13
24			Lifting(Laden)	mm/s	280
25			Lifting(Unladen)	mm/s	440
26		Gradeability	Laden	%	10
27			Unladen	%	10
28		Service weight	Include battery box	kg	3240
Driven	29	Tyre	Front×2		18×7-8
	30		Rear×1		18×7-8
	31	Motor	Driven motor	kw	4.5
	32		Pump motor	kw	11
	33	Battery	Standard(Optional)	V/Ah	48/400
	34	Operating pressure for attachment	Mpa		14.5

**M SERIES** 1.6t rear drive 3-wheel electric forklift mast

Type	Model	Max. fork height mm	Overall height				Free lift		Front Overhang mm	Tilt range		Capacity load capacity at 500mm Single tyre 1.6t kg
			Lowered mm	Extended		Without backrest mm	with backrest mm	FWD Deg		BWD Deg		
				Without backrest mm	With backrest mm							
2-stage mast	BM300	3000	1975	3490	4010	0	0	376	6.5	6.5	1600	
	BM330	3300	2125	3790	4310	0	0	376	6.5	6.5	1600	
	BM350	3500	2225	3990	4510	0	0	376	6.5	6.5	1600	
	BM370	3700	2325	4190	4710	0	0	376	6.5	6.5	1600	
	BM400	4000	2525	4490	5010	0	0	376	3.5	5	1600	
	BM450	4500	2775	4990	5510	0	0	376	3.5	5	1400	
	BM500	5000	3025	5490	6010	0	0	376	3.5	5	1250	
	BM550	5500	3325	5990	6510	0	0	376	3.5	5	1150	
full free 2-stage mast	BFM300	3000	1975	3490	4010	1510	990	376	6.5	6.5	1600	
	BFM330	3300	2125	3790	4310	1660	1140	376	6.5	6.5	1600	
	BFM350	3500	2225	3990	4510	1760	1240	376	6.5	6.5	1600	
	BFM370	3700	2325	4190	4710	1860	1340	376	6.5	6.5	1600	
	BFM400	4000	2525	4490	5010	2060	1540	376	3.5	5	1600	
Full free 3-stage mast	BTFM400	4000	1850	4490	5010	1385	865	376	3.5	5	1600	
	BTFM435	4350	1975	4840	5360	1510	990	376	3.5	5	1500	
	BTFM450	4500	2025	4990	5510	1560	1040	376	3.5	5	1400	
	BTFM480	4800	2125	5290	5810	1660	1140	376	3.5	5	1300	
	BTFM500	5000	2225	5490	6010	1760	1240	376	3.5	5	1250	
	BTFM550	5500	2390	5990	6510	1925	1405	376	3.5	5	1150	
	BTFM600	6000	2575	6490	7010	2110	1590	376	3.5	5	1050	
BTFM650	6500	2790	6990	7510	2325	1805	376	3.5	5	900		

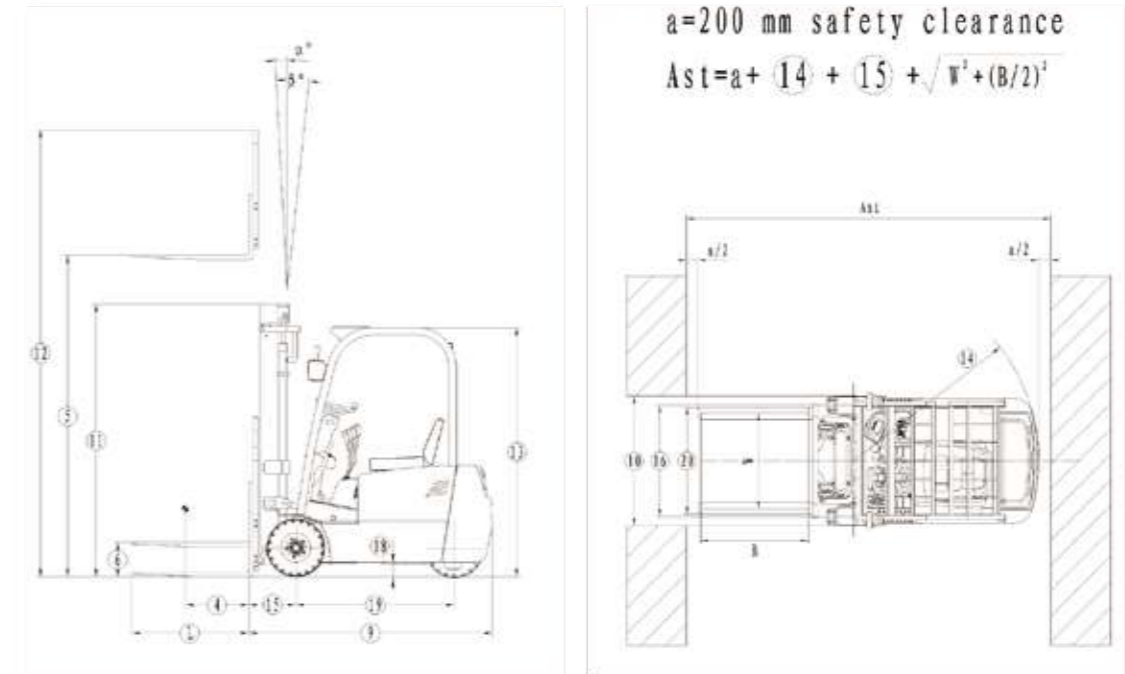

**REAR DRIVE  
3-WHEEL  
FORKLIFT 1.6T  
M SERIES**

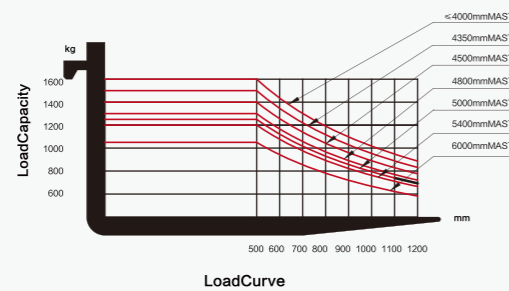

# COMPANY MEMORABILIA

2005	Dec	Zhejiang Maximal Forklift Co., Ltd was officially established.
2006	Oct	M series forklifts displayed at the 100th Canton fair.
2007	Nov	Maximal phase I project of the new factory finished.
2008	Jan	Structure of electric forklift was further optimized.
	Nov	Maximal was appointed by the General Logistics Department of the People's Liberation Army(PLA) to be supplier for Military Equipment.
2009	Mar	4.0T&5.0T and 8.0-10.0T diesel forklift were launched to enrich M Series.
	May	Maximal started to prepare the R&D of 16.0-18.0T diesel forklift.
2010	Nov	The first 4.5T electric forklift and 25.0T heavy duty forklift were displayed on Shanghai CeMAT.
	Dec	Maximal and Military Transportation University reached
2012		Maximal was honored as "state-level high-tech enterprise".
2013	May	Maximal 2WD 2.5/3.5T Rough Terrain forklift was launched to the market.
	July	Maximal Empty Container Handler was officially developed.
2014	Jun	Maximal electric stackers & pallet trucks were put into market.
	Aug	Maximal 2WD Rough Terrain forklift were extended to 4.0/5.0T.
	Dec	Maximal phase II project was finished.
2015	May	Maximal 3.5T 4WD Rough Terrain forklift was successfully developed. First Reach Stacker successfully was sold in domestic market.
2016	July	Maximal won the Chinese well-known trademark.
	Oct	1.8-3.5T C. 4WD Hydraulic rough terrain forklift was successfully launched.
2018	July	3.5-4.5T Sider-loader forklift was lanuched; Electric forklift with lithium battery started to be developed; 1.6-2.5T A series Reach truck was lanuched.
	June	<b>Hyster-Yale and Maximal officially completed its acquisition, Maximal began a new start.</b>